



Serie	-
Artikelnummer	P952-02
Kategorie	Betoninstallation
Montageart	-
EAN	4260182066669

Produkteigenschaften

Länge	260 mm
Breite	80 mm
Höhe	95 mm
Haftkraft	ca. 5.750 N / 575 kg
Gewicht	5,5 kg

Materialeigenschaften

Material	-
----------	---

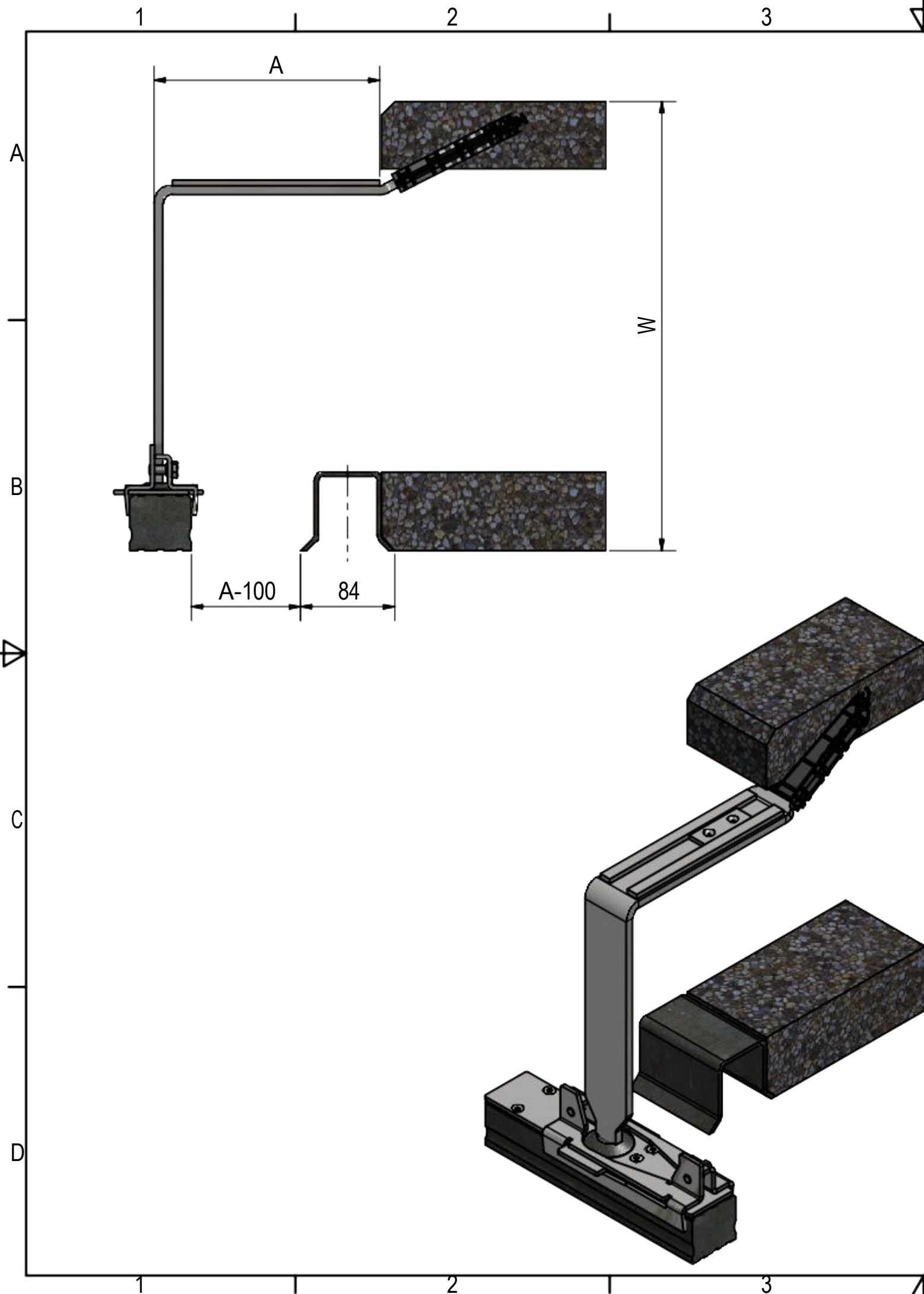

	4	5	6
	Wandstärke W:	Ausleger A:	Abstand A-100:
P952-180-140	180	140	40
P952-180-200	180	200	100
P952-200-140	200	140	40
P952-200-200	200	200	100
P952-220-140	220	140	40
P952-220-200	220	200	100
P952-240-140	240	140	40
P952-240-200	240	200	100
P952-250-140	250	140	40
P952-250-200	250	200	100
P952-300-140	300	140	40
P952-300-200	300	200	100
P952-350-140	350	140	40
P952-350-200	350	200	100
P952-360-140	360	140	40
P952-360-200	360	200	100
P952-365-140	365	140	40
P952-365-200	365	200	100
P952-400-140	400	140	40
P952-400-200	400	200	100

Maße in mm

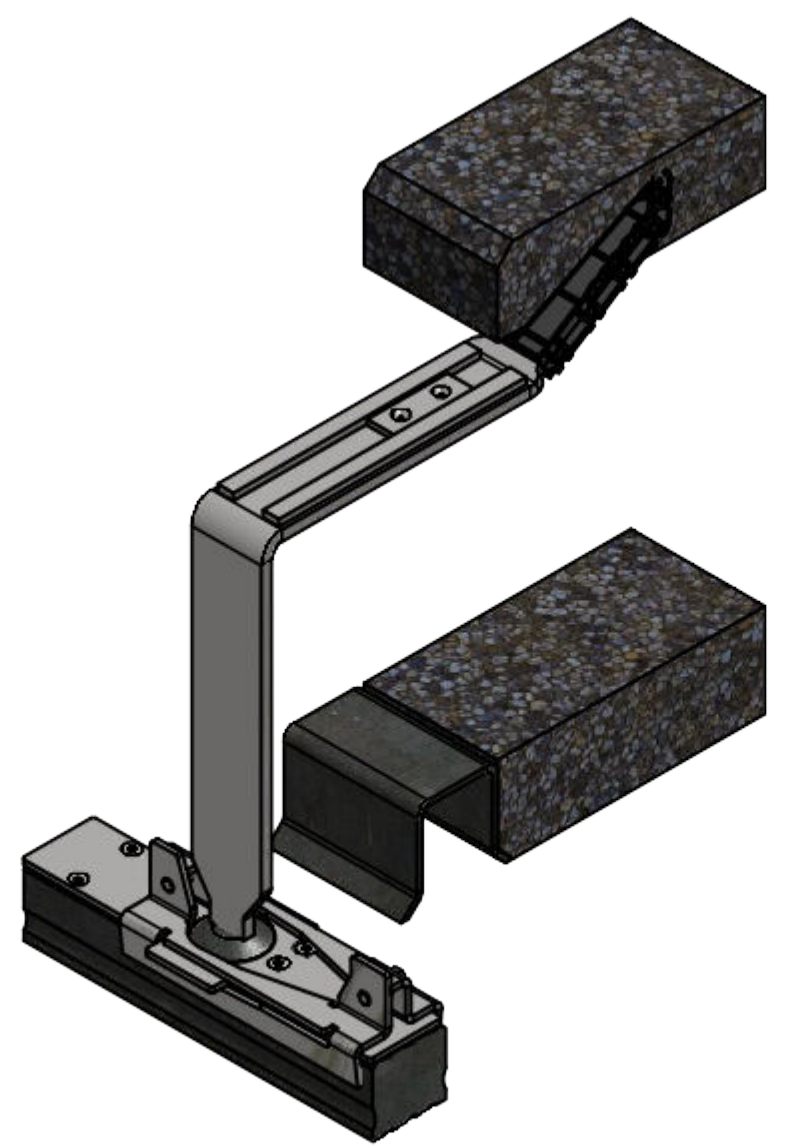

PRIMO [®]	Allgemeintoleranzen: DIN ISO 2768 T1-m DIN ISO 2768 T2-K	Material:
		P952-xxx-xxx SchwaBi Schwert
		1
		A3



Serie	-
Artikelnummer	P952-03
Kategorie	Betoninstallation
Montageart	-
EAN	4260182066676

Materialeigenschaften

Material	Kunststoff
----------	------------